

# RLM G5 Performer



## The high-performance, rugged, intelligent projector

For executive boardrooms, training facilities, reception area and customer centers and medium to large conference rooms, the RLM is the high contrast projector you can build on.

Display multiple information sources simultaneously. Switch input sources in no time. Enjoy an exceptional image quality and video performance.

The RLM Performer combines state of the art DLP™ technology from Texas Instruments with Barco's know-how in electronics, optics and mechanical design.

### Recommended applications:

- Collaborative meetings
- Presentation and training
- Videoconferencing
- Panoramic images using multiple channels

### Optimum performance for multiple-screen, multiple-channel applications

- **SCENERGIx** is a unique horizontal and vertical edge-blending software solution (standard available) that combines the processing of the data images projected by two (or more) projectors and displays one image without visible overlaps. Ideal for displaying panoramic data images on multiple-adherent screens.
- Color-uniformity over multiple screens is guaranteed thanks to the powerful DLP™ 3-chip technology.

### Powerful performance

- Exceptional video performance
- Advanced picture-in-picture
- Seamless source switching and transition effects

### Ready for demanding environments

- The sealed optical system makes the RLM G5 PERFORMER dust and smoke resistant
- Its dedicated rugged frame offers protection for the projector while making it easy to handle.

**BARCO**

Visibly yours

# RLM G5 PERFORMER specifications

## Light output

4000 ANSI lumens  
Brightness uniformity: 90%

## Resolution

1,024 x 768 pixels (native)

## Lamp

2 x 250 Watt UHP lamps in one module  
Typical lifetime of one module: 1000 hrs  
Max. lifetime of one module: 1500 hrs  
Easy & quick replacement of lamp-modules (within 2 minutes), even when projector is ceiling mounted with standard projector mount.  
Individual replacement possible

## Available lenses

Lens Type	Order No.
High quality fixed lenses	
RLD (0.8 : 1)	R9832640
TLD HB (0.8)(1.0)*	R9842040
TLD (1.2)(1.5)*	R9840770
High quality zoom lenses	
RLD (1.5-1.8:1)	R9832642
RLD (1.8-2.25:1)	R9832643
RLD (2.25-3.0:1)	R9832644
RLD (3.0-4.5:1)	R9832645
RLD (4.5-7.0:1)	R9832646
TLD HB (1.6 - 2.0)(2.0 - 2.5)*	R9842060
TLD HB (2.0 - 2.8)(2.5 - 3.5)*	R9842080
TLD HB (2.8 - 5.0)(3.5 - 6.3)*	R9842100
TLD HB (5.0 - 8.0)(6.3 - 10.0)*	R9842120
RLD adapter for TLD lenses	R9832650

(\* ) throw ratio on RLM G5

## Lens shift range (motorized)

Max. vertical shift from -20% to +125%  
Max. horizontal shift 70% (L+R)

## Contrast ratio

900 : 1 (full white/full black)

## Scan frequencies

Horizontal 15 kHz - 110 kHz  
Vertical 25 Hz - 150 Hz

## Special Features

- AUTO-IMAGE
- Standard light shutter
- Advanced digital zoom
- Advanced picture-in-picture
- Seamless source switching with effects
- Unique edge-blending software: SCENERGIX (only for data sources)

## AC Power

Auto ranging voltage: 92-240 VAC  
@ 50-60Hz

## Compatibility

- The RLM G5 PERFORMER is compatible with:
- All current video sources (PAL, SECAM, NTSC 3.58, NTSC 4.43) in Composite, S-Video, Component or RGB formats
  - All currently proposed HDTV extended and improved television standards (1080i, 720p)
  - All computer graphics formats from VGA, S-VGA, XGA, S-XGA to U-XGA
  - Most Macintosh computers
  - Electronic workstations with a resolution up to 1600x1200 pixels / 75 Hz
  - Most sources with a pixel clock up to 160 MHz
  - DVI sources up to SXGA+

## Inputs

- 1x Composite Video (BNC)
- 1x S-Video (4-pin mini-DIN)
- 1x DVI
- 1x VGA (D15 connector)
- 1x 5-BNC's capable of connecting:
  - RGBHV, RGBS, RGSB sources
  - Component video source
  - Up to 4 Composite video sources connected to the R, G, B & V connectors
  - S-Video sources (with the appropriate cabling of the Luminance and the Chrominance signal to the BNC connectors)
- 1x SDI with active loop-through
- 1x XLR rugged control connection
- 1x RS232C (D9 connector)
- Optional 10 base-T network connection

## Noise level

< 45dB

## Power consumption

Max. 1000 Watt

## Power dissipation

Max. 3415 BTU/h

## Safety regulations

Compliant with UL1950 and EN60950

## Electromagnetic interference

Barco's RLM complies with FCC rules & regulations, part 15 Class B, CE EN55022 class B and CCC

## Weight

Projector body: 25 kg/56 lbs.  
Projector body with frame: 30 kg/67 lbs.

## Dimensions

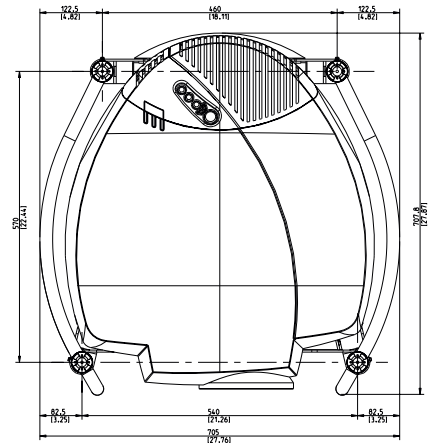
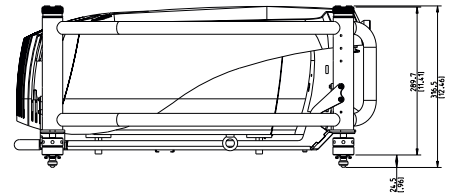
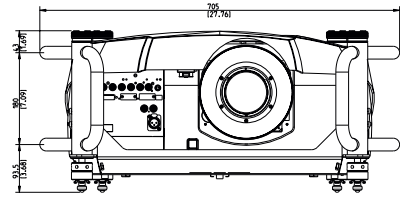

	cm	inch
Width	705	27.76
Length	707,8	27.87
Height	316,5	12.46

## Order information

RLM G5 PERFORMER (body only) R9010021  
Dual lamp package R9841880  
Ceiling mount R9841250

Ref. N° R599760 December 2004



Barco Simulation & Presentation is an ISO 9001 registered company. The information and data given are typical for the equipment described. However any individual item is subject to change without any notice. The latest version of this product sheet can be found on [www.presentation.barco.com](http://www.presentation.barco.com). DLP™ technology by Texas Instruments offers crystal clear images with superior quality. DLP is a trademark of Texas Instruments.

Barco Presentation  
Noordlaan5, B8520 Kuurne - Belgium  
Fax +32 56 36 86 51  
email: [info.presentation@barco.com](mailto:info.presentation@barco.com)

3240 Town Point Drive  
Kennesaw, GA 30144  
Tel. +1 770 218 3200 - Fax +1 770 218 3250  
email: [BPSmarketing@barco.com](mailto:BPSmarketing@barco.com)

**BARCO**

Visibly yours