

Encore Presentation System

Total Event Control



The Encore Presentation System is the most advanced video processing and presentation control system on the market today. The system provides source selection, advanced windowing features, seamless switching, video effects and integrated control for professional video presentations. Encore's modular, scalable architecture allows the system to support a wide variety of show configurations. The system can efficiently support from 1-32 screens with any combination of independent display or seamless wide-screen display elements.

Revolutionizing the event and entertainment industries

UP TO 12 INDEPENDENT WINDOWS WITH Z-LEVEL CONTROL

Each window can be resized and positioned in real time, with programmable Borders and Drop Shadows

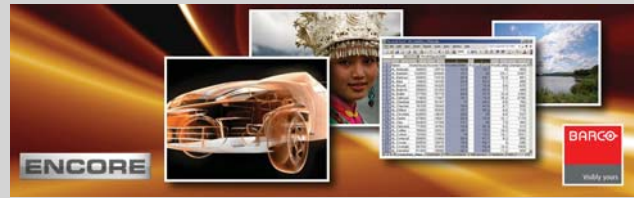

EXPANDABLE FROM 1 to 32 SCREENS

Encore supports any combination of single-screen, multi-screen or edge-blended widescreen applications.

NATIVE HIGH RESOLUTION BACKGROUND

Background transition effects are independent of the windowing channels.



SPECIAL EFFECTS

Seamless transitions, window border effects and advanced keying features are supported.

MODULAR SYSTEM ARCHITECTURE
Encore can be expanded as your needs change and system configurations can be tailored to efficiently meet application requirements.



EVENT CONTROL

Encore System Controllers provide easy-to-operate real-time control.

System Overview

From the smallest single-screen event to the most critical widescreen edge-blended presentation, only one system on the market handles every challenge with power and ease — the Encore Presentation System. Each Encore system consists of a Controller and one or more Video Processors, and each system is designed to grow in tandem with your creative requirements. With a full array of unsurpassed features, dynamic input flexibility and the superb quality of Barco Folsom scaling, Encore is the premiere choice for today's demanding presentation marketplace.

Three different Encore System Controllers are offered to meet the varying demands of unique system applications:

- The **Encore Controller SC** is designed for applications involving 24 input videos and can control shows with from 1-6 screens.
- The **Encore Controller LC** is designed for advanced applications involving up to 64 input videos and from 1-32 screens.
- The **Encore GC System**, that includes the Encore GC GUI and **Encore Control Unit (ECU)**, brings the power of the Encore LC and SC controllers to your desktop.

All three controllers are capable of controlling external routers for source selection and Encore Video Processor units to provide high-performance real-time video effects. The controllers provide a reliable, rapid power-up and true real-time performance for critical video processing sequences.

Features

- **Supports up to 12 Independent windows or 6 windows with seamless transitions**
- **(2) Native High Resolution Background channels provide background video with seamless transition effects**
- **Special effects**
 - Transition effects: cut, dissolve and wipe
 - Smooth PIP move & sizing controlled via Key Frames
 - Adjustable PIP aspect ratio
 - PIP borders, including drop shadows and soft edge
 - PIP clone (mirror and offset)
- **Keying**
 - Luminance key
 - Split key (key alpha and fill)
 - Reverse key (key on background)
 - Color key (Graphics)
 - Alpha mixing
- **(1) Native High Resolution Down Stream Key channel independent of PIP/KEY processing channels**
- **Video Processing**
 - 10-bit processing
 - 1:1 pixel sampling
 - Motion adaptive de-interlacing (SD & HD)
 - 3:2 and 2:2 pull down detect
 - Image cropping
 - Aspect ratio correction
- **Athena proprietary high-performance scaling**
- **Low video delay - less than 3 input fields**
- **Z-order Control (priority layers) for overlapping PIP or Key images**
- **Each mixer layer is dynamically re-assignable as a mixing (transitioning) PIP, or as two individual (SPLIT) non-transitioning PIP or Key images.**
- **Still frame : frame grab of background and down stream key sources**
- **Complete look-ahead preview**
- **Supports blended widescreen projection**
- **Output synchronization: free-run or vertically locked to NTSC/PAL blackburst or tri-level yync**
- **Edge blending**
 - ·10-bit processing
 - ·Variable overlap
 - ·Supports standard and pre-overlapped background sources
 - ·Edge blending (feathering)

The Encore Video Processor

The Encore Video Processor is packaged as a 3RU rack-mount unit that can be configured with one, two or three Mixer/Effect (M/E) boards to meet different application requirements. Models configured with one or two M/E boards can be easily upgraded.

Each M/E board provides two independent Athena scaler channels with universal inputs that handle both analog and digital video sources. The Athena scaler features 1:1 pixel sampling, motion adaptive de-interlacing for both standard and high definition sources, 3:2 and 2:2 pull-down detection, low video delay, aspect ratio correction, image cropping and real-time window re-sizing and positioning. Seamless transitions, window borders, drop shadows and a variety of keying effects are fully supported.

An Encore Video Processor configured with three M/E boards can scale six input sources to generate six PIP and/or Key effects. PIP and Key effects can be sized and positioned at any location on screen in real-time. Z-order control is used to assign overlay priorities to each PIP or Key. For superb flexibility, PIPs can be linked in pairs or used independently over any background image. Keying flexibility is equally creative, with the ability to self key, color key, fill with color matte, "split" key, and much more. Each Encore Video Processor also supports two native resolution background channels to provide a high resolution backdrop for PIPs and Keys, including seamless transitions. To complete the package, the unit supports a high resolution Down Stream Key (DSK) input.

Each Encore Video Processor's Output Board provides all output interface, blending and data-doubling functions required to support widescreen applications. The system supports output computer resolutions up to 1600x1200, analog HDTV resolutions including 720p, 1080i, 1080p, HD-SDI, 2048x1080p Digital Cinema video, and plasma display resolutions. Output synchronization is supported to lock the output frame rate to an externally applied NTSC/PAL black burst signal.



Encore Video Processor Rear Panel

VPx

The VPx offers a cost effective solution for wide screen Encore destinations. In a blended wide screen configuration in which two or more Video Processors are used, VPx can be used to replace the second (and higher) Video Processors without compromising image quality or functionality.

In a blended widescreen configuration, VPx operates like a standard VP providing the same layering capabilities, features and effects. The VPx also includes the same output connectors as the standard VP.

The VPx can also be used as a multiple preview display processor. By sending the preview outputs from other Encore VP and VPx units to the "multi-view" VPx, you can combine multiple preview outputs on a single display. On the "multi-view" monitor, preview outputs can be arranged in any size or location, and the monitor display itself is managed from any of the Encore Controllers.

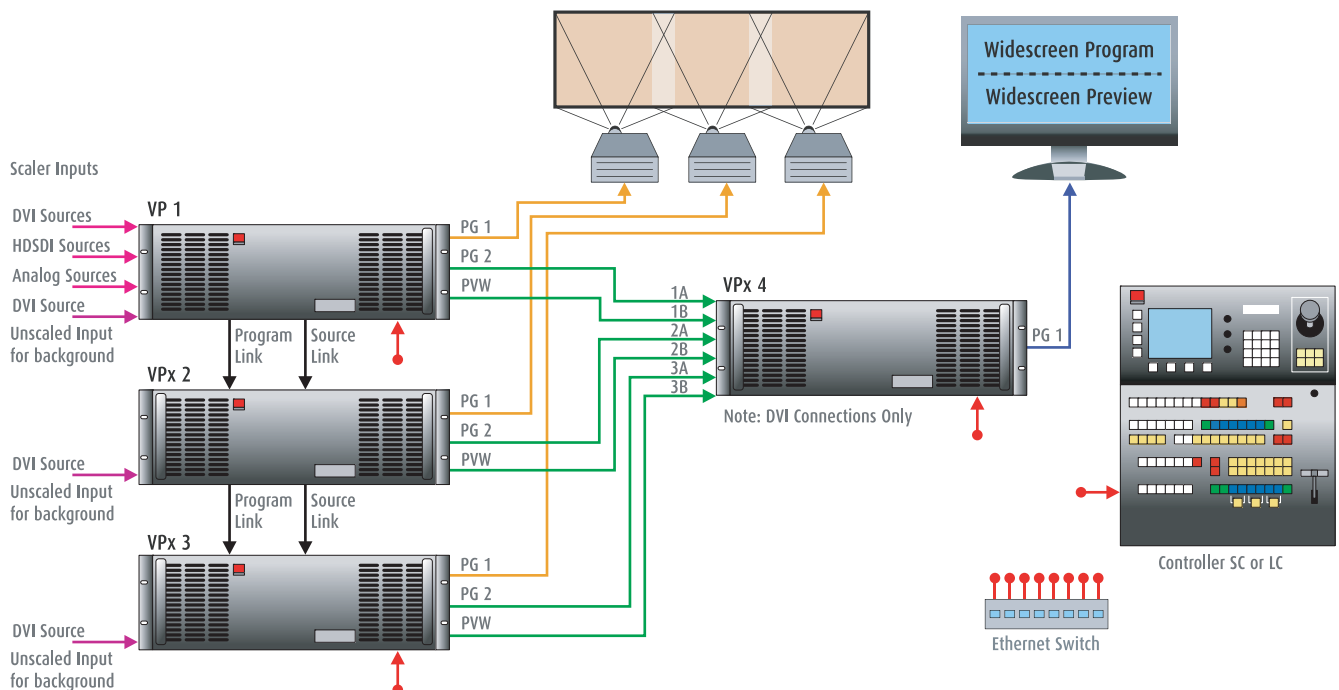

Creating Effects with Encore

The Encore Video Processor can be configured with one, two, or three mixer (M/E) boards, enabling you to create a variety of dynamic and unique effects on screen utilizing any or all of Encore's visual layers:

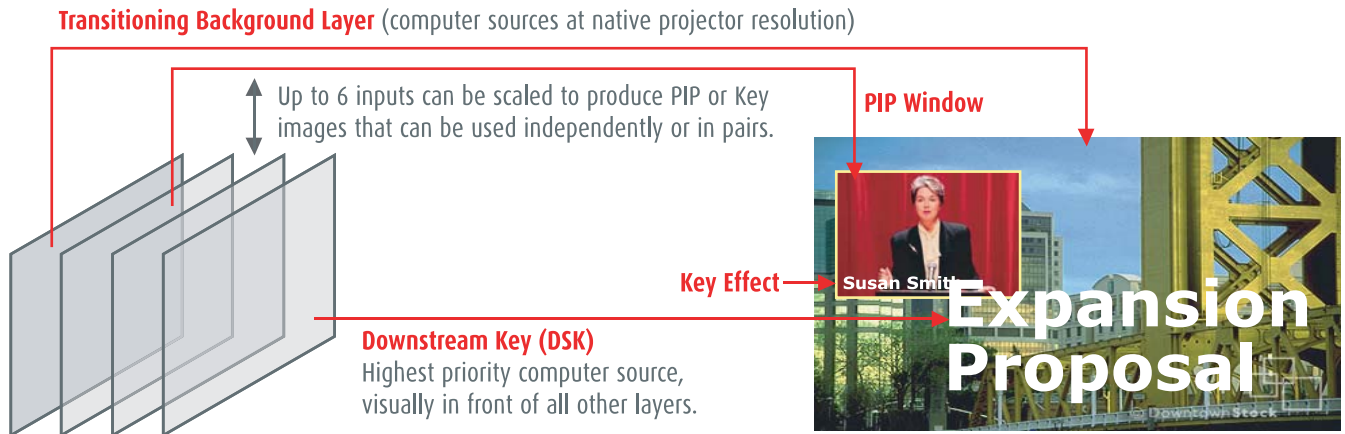

Single Mixer Effects

A single Mixer Encore system provides two backgrounds, two scaleable mixer layers plus an unscaled DSK. Note that if the DSK is in use, the background cannot transition between A and B. The DSK and background channels are unscaled, in all cases.

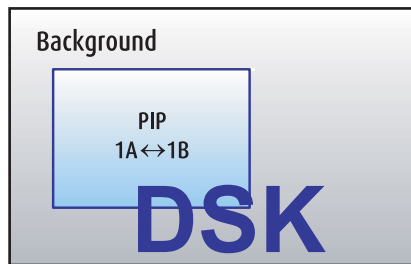

Non-transitioning background (either A or B), (1) transitioning PIP, DSK.

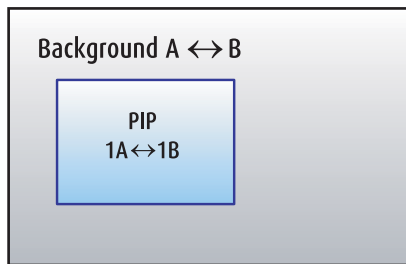

Transitioning background, (1) transitioning PIP (no DSK)

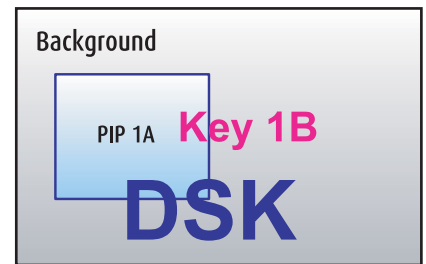

Non-transitioning background, (1) Pip, (1) Key, DSK

Dual Mixer Effects

A dual Mixer Encore system provides two backgrounds, a total of four scalable layers in the two Mixers, plus an unscaled DSK.

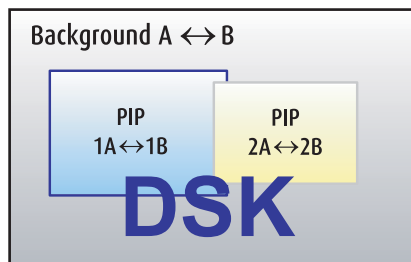

Transitioning background, 2 transitioning PIPs plus DSK

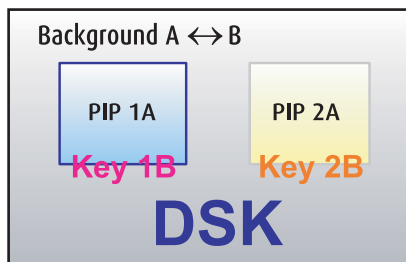

Transitioning background, 2 independent PIPs and 2 Keys, DSK

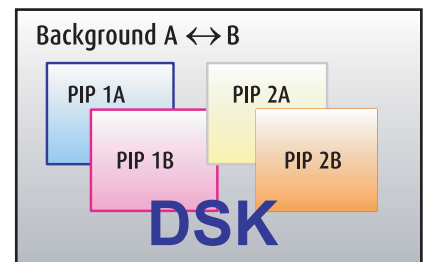

Transitioning background, 4 independent PIPs (or Keys), DSK

Triple Mixer Effects

A triple Mixer Encore system provides two backgrounds, a total of six scalable layers in the three Mixers plus an unscaled DSK.

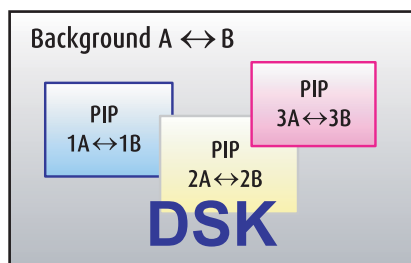

Transitioning background, 3 transitioning PIPs, DSK

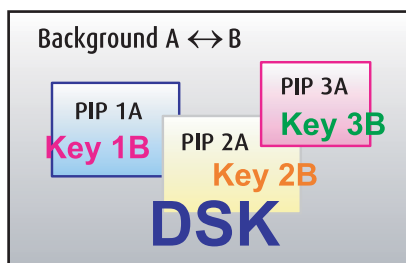

Transitioning background, (1) non-transitioning PIP/Key on each mixer, DSK

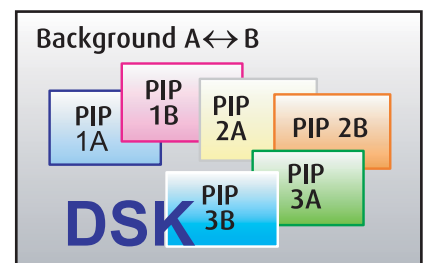

Transition background, six independent (non-transitioning) PIPs (or Keys), DSK

Total Event Control

The Encore System Controllers support events by allowing integrated control of multiple Encore Video Processors in addition to matrix switchers.

Encore Controller LC

Preset Buttons

Buttons enable you to store and recall Controller setups. Each button represents a single "look" of the overall projected image.

System Touch Screens

Used for system configuration, setup and operational adjustments, such as PIPs and Keys.

System Keypad

Provides direct access to all system configuration, setup and status menus.

Alphanumeric Touch Screen

Enables you to enter and change numeric values on the Touch Screen.

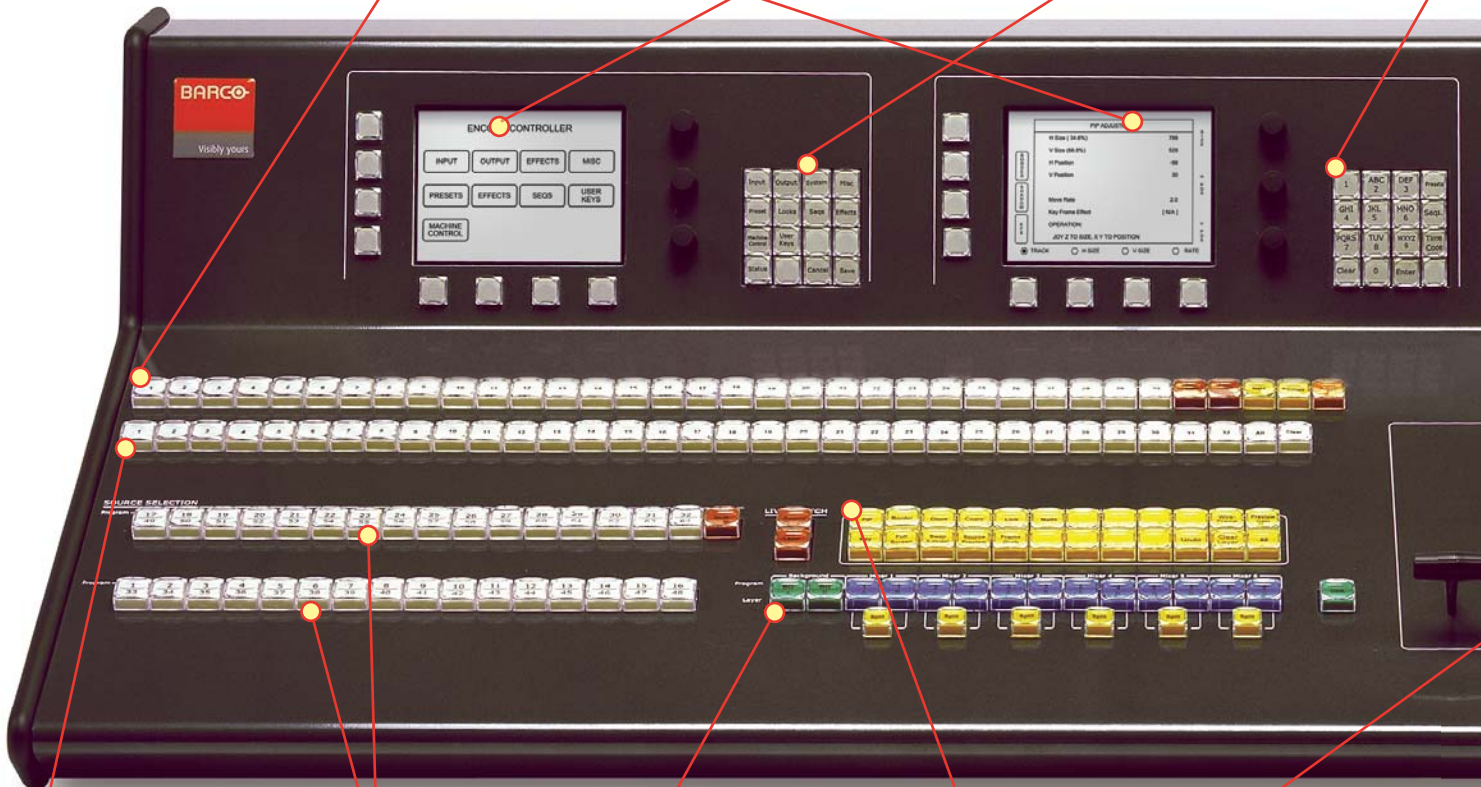

Destination Bus

Each button selects an active destination (e.g., single screen, widescreen, aux) to which you can route the Controller's output.

Source Selection Bus

Each button represents a source that you can route to PIPs, Keys and Aux destinations.

Layer Control Section

Buttons select the layer(s) that will transition to or from Program. Split buttons control the "mode" of each mixer

Layer Functions Section

Buttons in this section apply to the active (blinking) layer, enabling you to change the layer's mode and attributes.

Transition Section

Includes the T-Bar for manually mixing sources, plus dedicated buttons for cuts and auto-transitions.

Group

To simplify selection of "Group" programs or modes.



Mixer buttons provide two unique modes of operation. In "Mix" mode, layers are ganged together. In "Split" mode, each layer works independently.



Each Touch Screen provides fast, easy and precise access to all menus and functions.

Controller Features

	Small Controller	Large Controller
Encore Processors supported	32	32
Widescreen support	Yes	Yes
External Router Control	Yes	Yes
Inputs supported	24	64
Destinations supported	6	32
Available Presets	64	900
Layers supported	1 DSK 6 Scaled Inputs (PIP or Key) 1 Transitioning background	1 DSK 12 Scaled Inputs (PIP or Key) 1 Transitioning background
User-selectable Transition Functions	Yes	Yes
Available User-defineable Keys	None	100
Joystick & T-Bar	Yes	Yes
320 x 240 graphic displays	1	2
Light sticks	2	3
PS/2 Keyboard support	Yes	Yes
Communication	Ethernet, RS-232	Ethernet, RS-232
Field Upgradeable	Yes	Yes
Tally support	8	8

Keypad
enter and
values on the

Adjustment Panel

Joystick enables you to adjust PIPs, Keys and other parameters. Dedicated buttons allow you to change the Joystick's function.

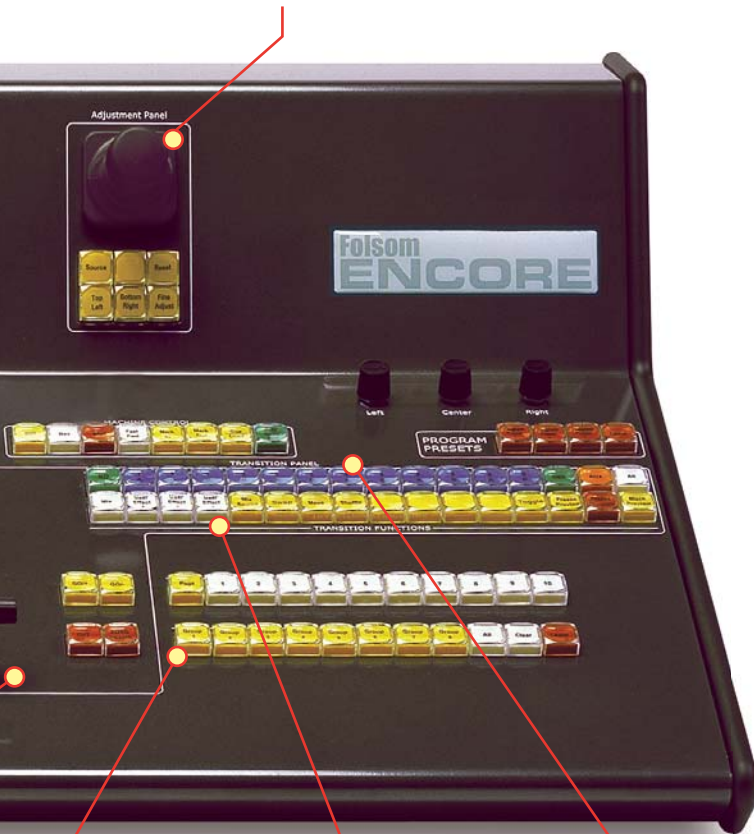

Top Control Section
Simplify destination
transition process, each
"up" button can be
programmed to activate one
or more destinations.

Transition Functions

Buttons set parameters for the current transition and mode, such as mix source, toggle, swap, move and black preview.

User Key Section

Each button stores PIP and Key parameters, enabling you to copy between layers and mixers.

The joystick is multi-functional. Use it to size, position and crop both PIP and Keys, or use it to adjust the value of a highlighted parameter on the Touch Screen.



Encore Controller SC

Sample Encore Configurations

Single Screen Configuration

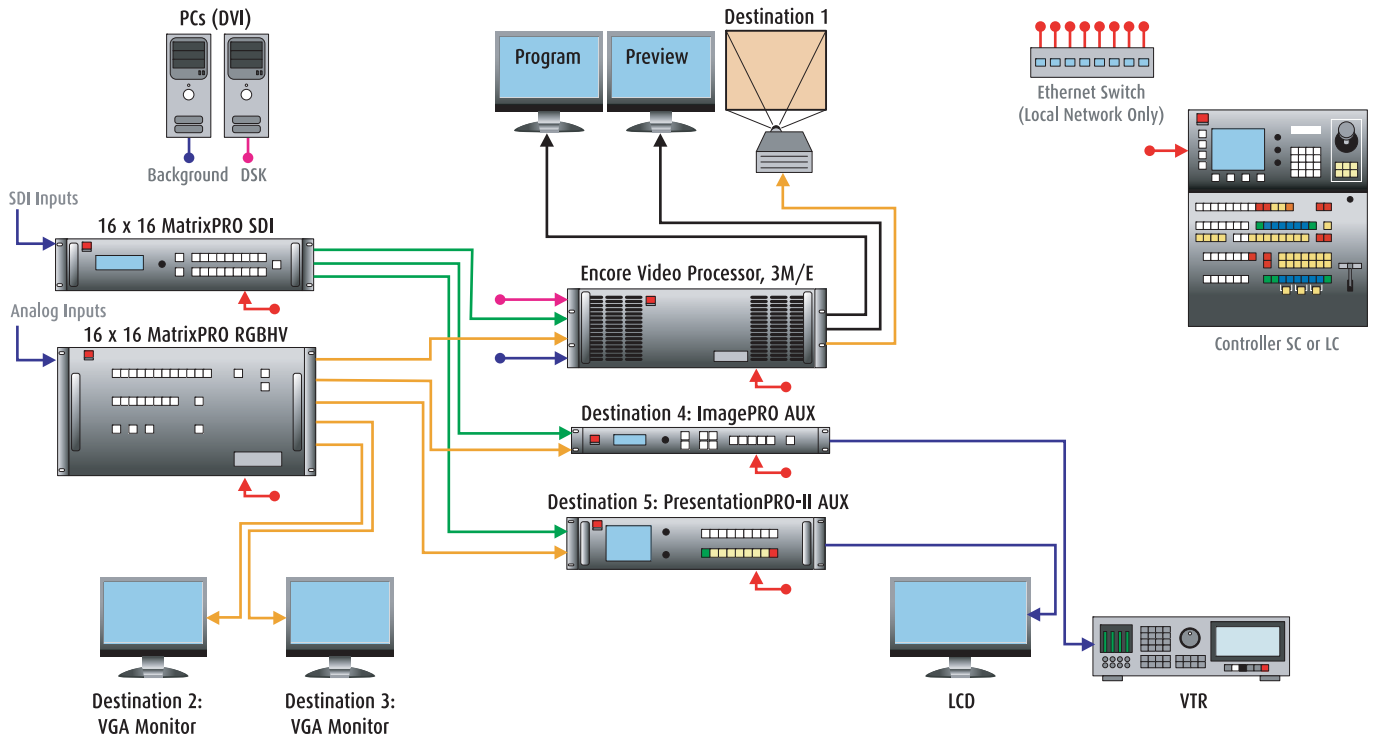

- Non-stack system, up to 6 layers
- 3M/E Video Processor (x1), SDI Router (x1), RGBHV Router (x1)
- 5 Destinations: (1) Projector, (2,3) Aux monitors, (4) ImagePRO Aux, (5) PresentationPRO-II Aux

Multi Screen Configuration

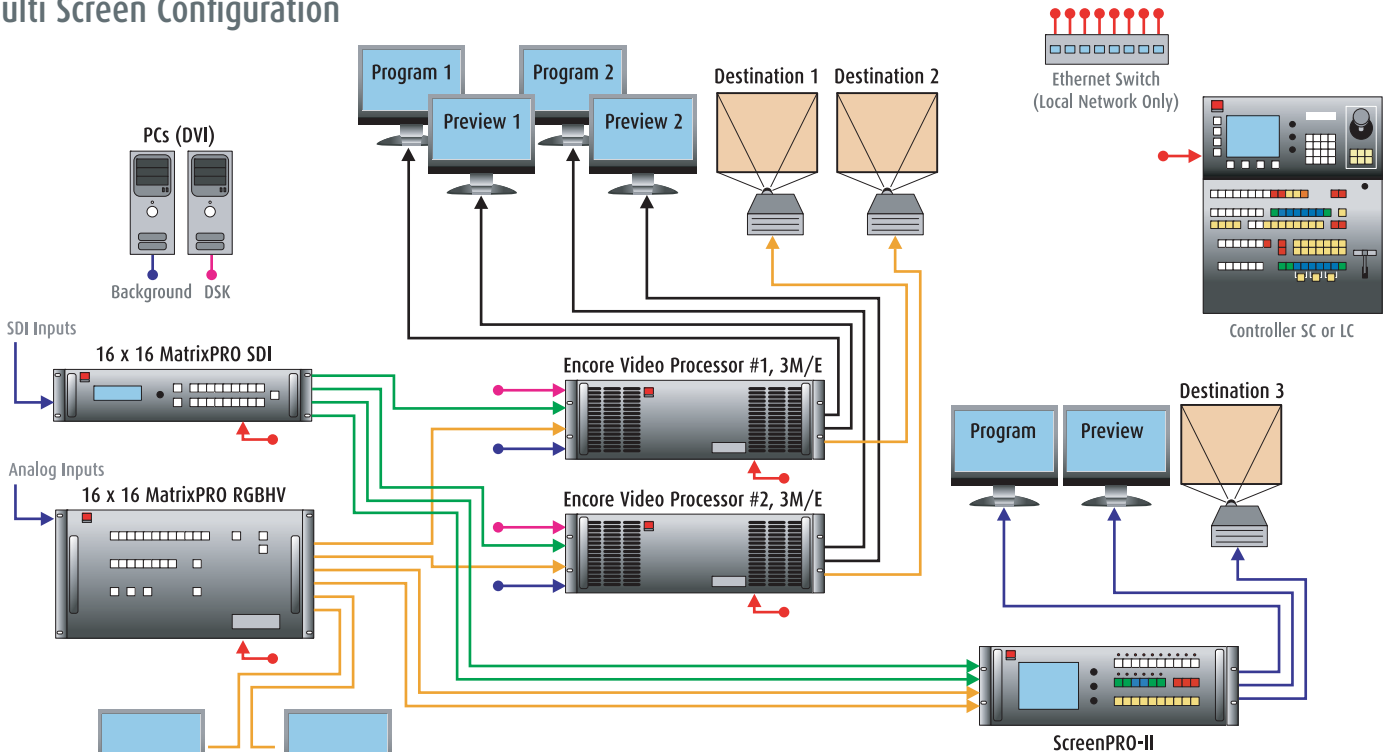

- Non-stack system, up to 6 layers
- 3M/E Video Processor (x2), SDI Router (x1), RGBHV Router (x1)
- 5 Destinations: (1,2) Projectors, (3) ScreenPRO-II, (4,5) Aux monitors

Widescreen Configuration

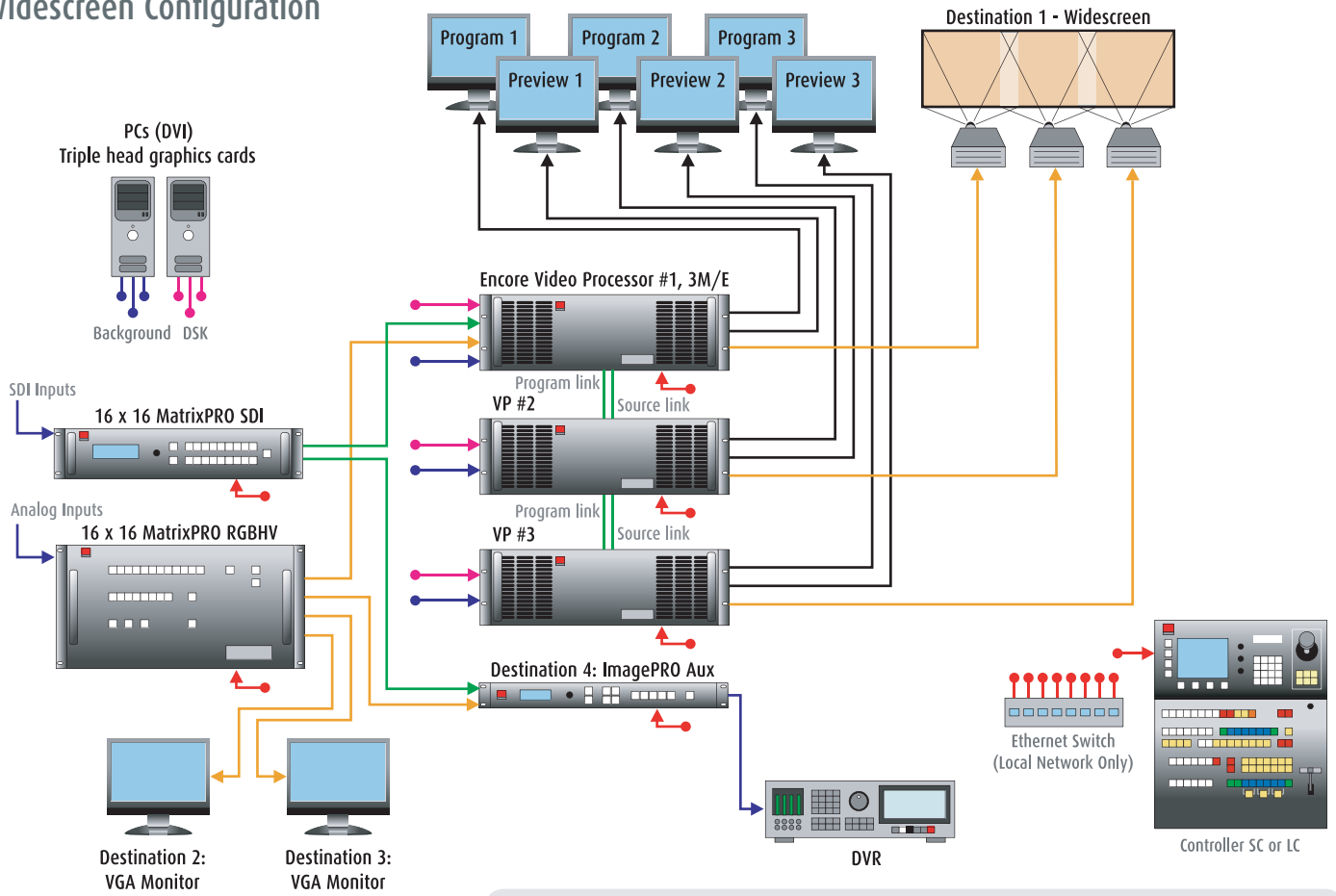

- Non-stack system, up to 6 layers
- 3M/E Video Processor (x3), SDI Router (x1), RGBHV Router (x1)
- 4 Destinations: (1) Projector wide ecreen, (2,3) Aux monitors, (4) ImagePRO Aux

Single-screen "stack" Configuration

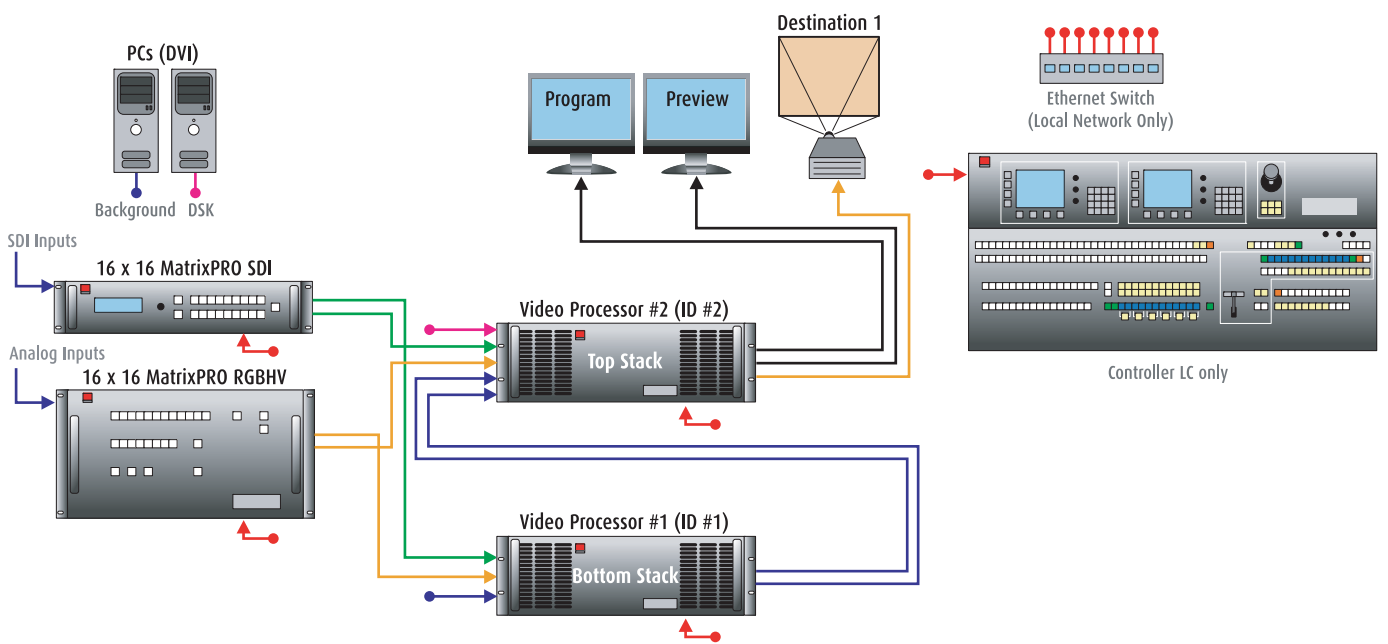

- Stack system, up to 12 layers (Controller LC only)
- 3M/E Video Processor (x2), SDI Router (x1), RGBHV Router (x1)
- Destinations: (1) Projector

Integration with Signal Routers

The use of high quality routers is an integral part of the Encore system. Barco offers analog and digital routers including SDI, HD/SDI and DVI units that are fully compatible with Encore. All of our routers are designed and tested to ensure quality, reliability, robustness and ease of use. The Encore system is also compatible with other manufacturers' routers.



MatrixPRO Serial Digital Series handles up to 16 digital SD-SDI/HD-SDI input signals



The MatrixPRO 8x8 DVI router provides versatile switching for up to 8 DVI signals



The MatrixPRO Analog Series can route from 4 to 32 RGBHV signals

Encore Configurator

The Encore Configurator GUI enables operators to pre-configure the system prior to arrival on site. The GUI steps you through basic screen layout, screen details, and router setup. The program includes a calculator for blended widescreen applications that determines the amount of overlap and number of processors required for a particular screen size. The Configurator also includes set up diagrams designed to ease your on-site preparations, plus backup and restore functions that simplify your ability to load and safely store all Encore configurations.

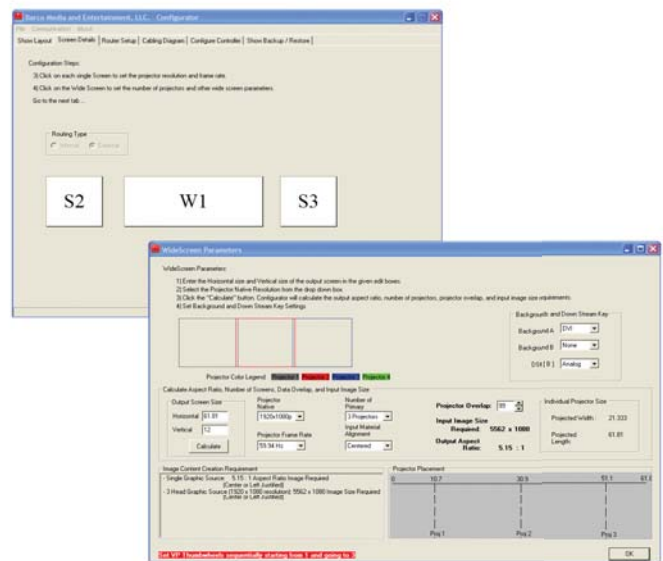

Configurator GUI

Encore GC



Encore GC GUI

Encore GC gives operators the power of the Encore Controllers at the click of a mouse. The Encore GC replaces the hardware controller in applications where the LC or SC is not required. All system configuration, layer and preset functions can be performed from the Graphical User Interface, just as they are from the controllers. In addition, the Encore GC functions as a pre-show design tool, where presets and "looks" can be established off-line and then downloaded to the system at a later time. The Encore GC system also includes the **Encore Control Unit (ECU)**, which interfaces easily with other control systems, and also provides standalone time line functionality for completely independent operations.



Encore Control Unit (ECU)

Encore Video Processor Specifications

Inputs		
Mixer/Effects Channels (2 per m/e board)	Analog Inputs	RGBHV/RGBS/RGsB computer video, YPbPr video (SD or HD), S-video, or Composite video on 15-pin HD connector
	SD and HDSDI Input	per SMPTE 259M-C (NTSC/PAL resolution) SMPTE 292M (HDTV) on BNC connector
	DVI Input	per DDWG 1.0 on DVI-I connector
	Input Resolutions	<ul style="list-style-type: none"> ·NTSC/PAL ·Computer Resolutions VGA (640 x 480) through UXGA (1600 x 1200) ·HDTV Resolutions up to 1920 x 1080 (720p, 1080i, 1080p) ·2048 x 1080p (Digital Cinema format) ·Plasma Display Resolutions
Native Resolution Background Channels (2 per M/E board)	Analog Inputs	RGBHV computer video on DVI-I connector
	DVI Input	per DDWG 1.0 on DVI-I connector
	Input Resolutions	<ul style="list-style-type: none"> ·Computer Resolutions: SVGA (800 x 600) through UXGA (1600 x 1200) ·HDTV Resolutions (720p, 1080p) ·2048 x 1080p (Digital Cinema format) ·Plasma Display Resolutions
Downstream Key Input (1 per Encore Video Processor)	Analog Inputs	RGBHV computer video on DVI-I connector
	DVI Input	per DDWG 1.0 on DVI-I connector
	Input Resolutions	<ul style="list-style-type: none"> ·Computer Resolutions: SVGA (800 x 600) through UXGA (1600 x 1200) ·HDTV Resolutions (720p, 1080p) ·2048 x 1080p (Digital Cinema format) ·Plasma Display Resolutions
Frame Lock Input		NTSC/PAL black burst reference on BNC Connector
Outputs		
Preview Output	Analog Outputs	RGBHV/RGBS/RGsB, YPbPr video (SD or HD), on 15-pin HD connectors
	DVI Output	per DDWG 1.0 on DVI-I connector
Program Output 1	Function	Main output. Contains data-doubled data on widescreen applications
	Analog Outputs	RGBHV/RGBS/RGsB, YPbPr video (SD or HD), on 15-pin HD connectors
	DVI Output	per DDWG 1.0 on DVI-I connector
	Optional HDSDI Output	per SMPTE 259M-C (NTSC/PAL resolution) SMPTE 292M (HDTV) on BNC connector (Program Out)
Program Output 2	Function	Second buffered program output or a monitoring program output
	Analog Outputs	RGBHV/RGBS/RGsB, YPbPr video (SD or HD), on 15-pin HD connectors
	DVI Output	per DDWG 1.0 on DVI-I connector
	Optional HDSDI Output	per SMPTE 259M-C (NTSC/PAL resolution) SMPTE 292M (HDTV) on BNC connector (Program Out)
Output Resolutions		<ul style="list-style-type: none"> ·Computer Resolutions VGA (640 x 480) through UXGA (1600 x 1200) ·HDTV Resolutions up to 1920 x 1080 (720p, 1080i, 1080p) ·2048 x 1080 (Digital Cinema format) ·Plasma Display Resolutions
Communication		RS-232, Ethernet connection (with TCP/IP)
Mechanical		3 RU Rackmount Chassis
Power		120-240 VAC - 50/60 Hz., Autoselecting 1.0A maximum

Barco nv - Media & Entertainment Division

Noordlaan 5, 8520 Kuurne, Belgium
T +32 56 36 80 47 - F +32 56 36 83 86
email: sales.event@barco.com

11101 Trade Center Drive,
Rancho Cordova, CA 95670, USA
T +1 916 859 2500 - F +1 916 859 2515

